

FLUID COOLING | Industrial BOL Series

AIR COOLED BOL

BRAZED ALUMINUM CONSTRUCTION

Features

- Bar and Plate Brazed Aluminum Core
- Rugged, lightweight, and compact
- Provides the best heat transfer per given envelope size while minimizing pressure drop
- Air-side fin design minimizes fouling and static pressure ensuring long-term, reliable performance
- Welded fittings/ports and manifolds ensure structural integrity
- Standard SAE ports – NPT and BSPP ports available
- Customized units are available to meet your specific performance requirements
- Additional capabilities for radiators, charge-air-coolers, condensers, and multi-circuit units
- T-BAR core optional for high viscosity oils or other highly fouling fluids. *See T-Bar Performance Curve
- Low Noise Option Available

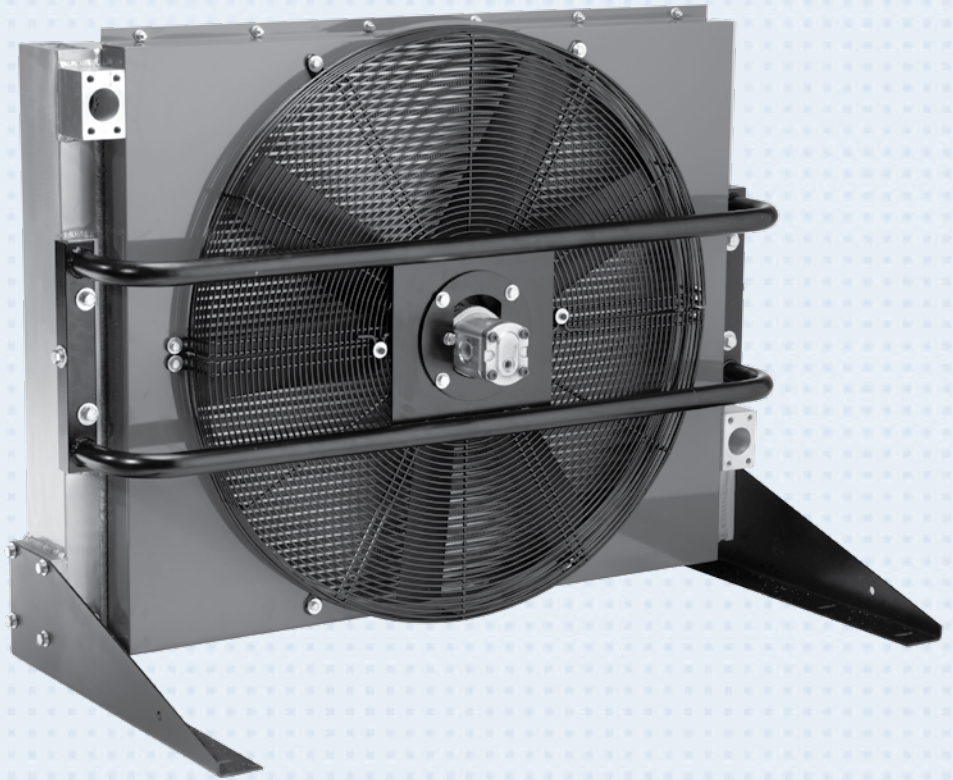

Ratings

Maximum Operating Pressure

250 psi (17 BAR)

Maximum Operating Temperature

300° F (150° C)

Materials

Mounting Feet Steel

Standard Core Brazed Aluminum Bar and Plate

- Tanks – 5052 Aluminum
- Nose Bar & Little Bar – 3003-H Aluminum
- Air Fin, Plate, Turbulator & End Plate – 3003-O Aluminum

Fanguard Steel

Connectors Aluminum

Fan Aluminum Hub, Plastic Blades

Shroud Steel

Motor TEFC & IEC

T BAR™

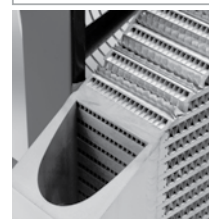

OPTIONAL T-BAR CORE
SECTION CUTAWAY

Dimensions

BOL-4

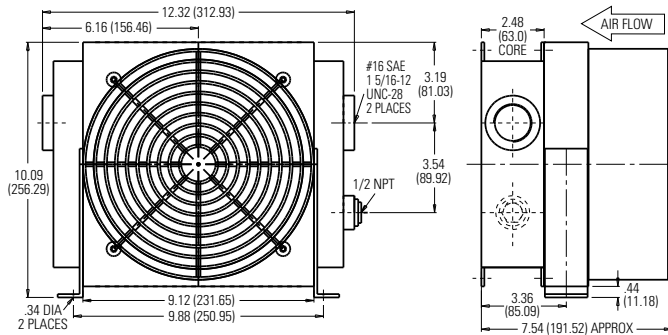

BOL-8 through BOL-1600

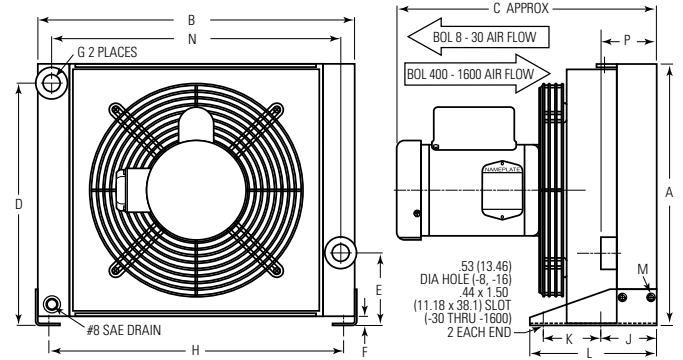

BOL-2000

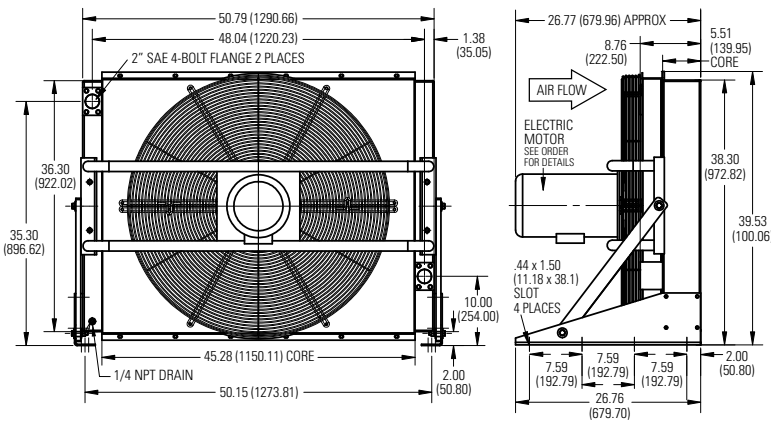

Model	A	B	C	D	E	F	G	H	J	K	L	M	N	P	Approx. Ship Wt. lbs (Kg)
BOL-4	See diagram above														18 (8.16)
BOL-8	12.44 (315.98)	15.75 (400.05)	14.72 (373.89)	11.30 (287.62)	3.27 (83.06)	.55 (13.97)	#12 SAE	14.53 (369.06)	3.07 (77.98)	3.50 (88.90)	7.36 (186.94)	M8 Bolt (2PL)	14.01 (255.85)	3.48 (88.40)	45 (20.4)
BOL-16	16.24 (412.50)	19.69 (500.13)	16.16 (410.46)	15.06 (382.52)	4.51 (114.56)	.57 (14.48)	#12 SAE	18.30 (464.82)	3.35 (85.09)	3.74 (95.00)	7.87 (199.90)	M8 Bolt (2PL)	17.95 (455.93)	3.46 (87.88)	55 (24.94)
BOL-30	20.69 (525.53)	26.38 (670.06)	18.23 (463.04)	19.49 (495.05)	5.26 (133.60)	1.32 (33.53)	#20 SAE	24.74 (628.40)	4.25 (107.95)	5.00 (127.00)	10.00 (254.00)	M10 Bolt (4PL)	24.34 (618.24)	5.28 (134.11)	125 (56.70)
BOL-400	19.83 (503.68)	22.45 (570.23)	18.80 (477.52)	17.31 (439.67)	6.50 (165.10)	2.00 (50.80)	#20 SAE	22.30 (566.42)	4.25 (107.95)	5.00 (127.00)	10.00 (254.00)	M10 Bolt (4PL)	20.08 (510.03)	5.20 (132.08)	148 (67.13)
BOL-725	24.37 (619.00)	30.32 (770.13)	18.60 (472.44)	21.60 (548.64)	6.50 (165.10)	2.00 (50.80)	#20 SAE	30.17 (766.32)	4.25 (107.95)	5.00 (127.00)	10.00 (254.00)	M10 Bolt (4PL)	27.95 (709.93)	5.20 (132.08)	170 (77.11)
BOL-950	28.82 (732.03)	37.03 (940.56)	22.69 (576.33)	24.55 (623.57)	9.50 (241.30)	2.00 (50.80)	2" SAE 4-Bolt Flange	35.89 (911.61)	6.05 (153.67)	9.20 (233.68)	16.00 (406.40)	M10 Bolt (4PL)	34.26 (870.20)	7.01 (178.05)	300 (136.08)
BOL-1200	28.82 (732.03)	40.96 (1040.38)	24.07 (611.38)	24.55 (623.57)	5.50 (139.70)	2.00 (50.80)		40.31 (1023.87)	6.05 (153.67)	9.20 (233.68)	16.00 (406.40)	M10 Bolt (4PL)	38.19 (970.03)	7.01 (178.05)	430 (195.04)
BOL-1600	36.89 (937.00)	40.96 (1040.38)	25.45 (646.43)	32.62 (828.55)	9.50 (241.30)	2.00 (50.80)		40.31 (1023.87)	6.05 (153.67)	9.20 (233.68)	16.00 (406.40)	M10 Bolt (4PL)	38.19 (970.03)	7.01 (178.05)	515 (233.60)
BOL-2000	See diagram above														582 (264.00)

Note: We reserve the right to make reasonable design changes without notice. All dimensions are in inches and (millimeters).



Specifications

Electric Motor Information (60 Hz Nema Frame)

Model	CMM	CFM	Motor HP	Voltage	Phase	Full Load Amps 230V	Frequency	RPM	Frame	Thermal Overload	Sound dB(A) at 3ft
BOL-4	31.14	1100	1/4	230	1	—	60 Hz	2850	—	—	73
BOL-8	22.65	800	1/3	115/230	1	3.0	60 Hz	3450	48C	No	80
BOL-8	22.65	800	1/3	208-230/460	3	1.4	60 Hz	3450	48C	No	80
BOL-16	40.35	1425	1/2	115/230	1	3.7	60 Hz	3450	48C	No	85
BOL-16	40.35	1425	1/2	208-230/460	3	2.2	60 Hz	3450	48C	No	85
BOL-30	62.29	2200	1/2	115/230	1	3.7	60 Hz	1725	56C	No	85
BOL-30	62.29	2200	1/2	208-230/460	3	2.0	60 Hz	1725	56C	No	85
BOL-400	62.29	2200	1	115/230	1	6.0	60 Hz	3450	56C	No	97
BOL-400	62.29	2200	1	208-230/460	3	3.2	60 Hz	3450	56C	No	97
BOL-725	101.94	3600	1-1/2	115/230	1	8.5	60 Hz	3450	56C	No	100
BOL-725	101.94	3600	1-1/2	208-230/460	3	4.8	60 Hz	3450	56C	No	100
BOL-950	133.10	4700	1-1/2	115/230	1	8.6	60 Hz	1725	145TC	No	92
BOL-950	133.10	4700	1-1/2	208-230/460	3	4.6	60 Hz	1725	145TC	No	92
BOL-1200	198.22	7000	3	208-230/460	3	8.8	60 Hz	1725	182TC	No	94
BOL-1600	223.75	7900	5	208-230/460	3	13.4	60 Hz	1725	184TC	No	96
BOL-2000	285.00	11000	7.5	230/460	3	24.8	60 Hz	1725	213TC	No	98

Electric Motor Information (50 Hz IEC Frame)

Model	CMM	CFM	KW	Voltage	Phase	Frequency	RPM	Frame	Sound dB(A) at 3ft
BOL-4	28.4	1003	0.20	220/380	1	50 Hz	2600	—	73
BOL-8	18.89	667	0.75	220/380	3	50 Hz	2700	80	74
BOL-16	33.64	1188	0.75	220/380	3	50 Hz	2700	80	79
BOL-30	54.76	1934	2.20	220/380	3	50 Hz	1410	100	77
BOL-400	51.93	1834	3.00	220/380	3	50 Hz	2800	100	81
BOL-725	84.95	3000	3.00	220/380	3	50 Hz	2800	100	84
BOL-950	110.92	3917	2.20	220/380	3	50 Hz	1410	100	83
BOL-1200	165.20	5834	5.50	220/380	3	50 Hz	1430	132	88
BOL-1600	186.44	6584	5.50	220/380	3	50 Hz	1430	132	89
BOL-2000	331.31	11700	5.00	220/380	3	50 Hz	1430	132	93

Hydraulic Motor Information

Model	Oil Flow Required GPM (LPM)	Min. Pressure Required PSI (BAR)	Motor IN ³ /REV (CM ³ /REV) Displacement	Sound dB(A) at 3 ft.
BOL-4	3.3 (12.49)	400 (27.58)	0.22 (3.6)	80
BOL-8	3.3 (12.49)	400 (27.58)	0.22 (3.6)	80
BOL-16	3.3 (12.49)	500 (34.47)	0.22 (3.6)	85
BOL-30	3.4 (12.87)	500 (34.47)	0.45 (7.3)	85
BOL-400	3.3 (12.49)	425 (29.30)	0.22 (3.6)	97

Model	Oil Flow Required GPM (LPM)	Min. Pressure Required PSI (BAR)	Motor IN ³ /REV (CM ³ /REV) Displacement	Sound dB(A) at 3 ft.
BOL-725	3.3 (12.49)	675 (27.58)	0.22 (3.6)	100
BOL-950	10.1 (38.23)	300 (34.47)	1.4 (22.9)	92
BOL-1200	10.1 (38.23)	700 (34.47)	1.4 (22.9)	94
BOL-1600	10.1 (38.23)	1100 (29.30)	1.4 (22.9)	96
BOL-2000	10.1 (38.23)	1650 (113.76)	1.4 (22.9)	98

Notes: Maximum Pressure is 2000 psi. Stated Minimum Operating Pressure is at Inlet Port of Motor. 1000 psi Allowable Back Pressure.

Performance Curves

BOL Models with Optional T-BAR Core

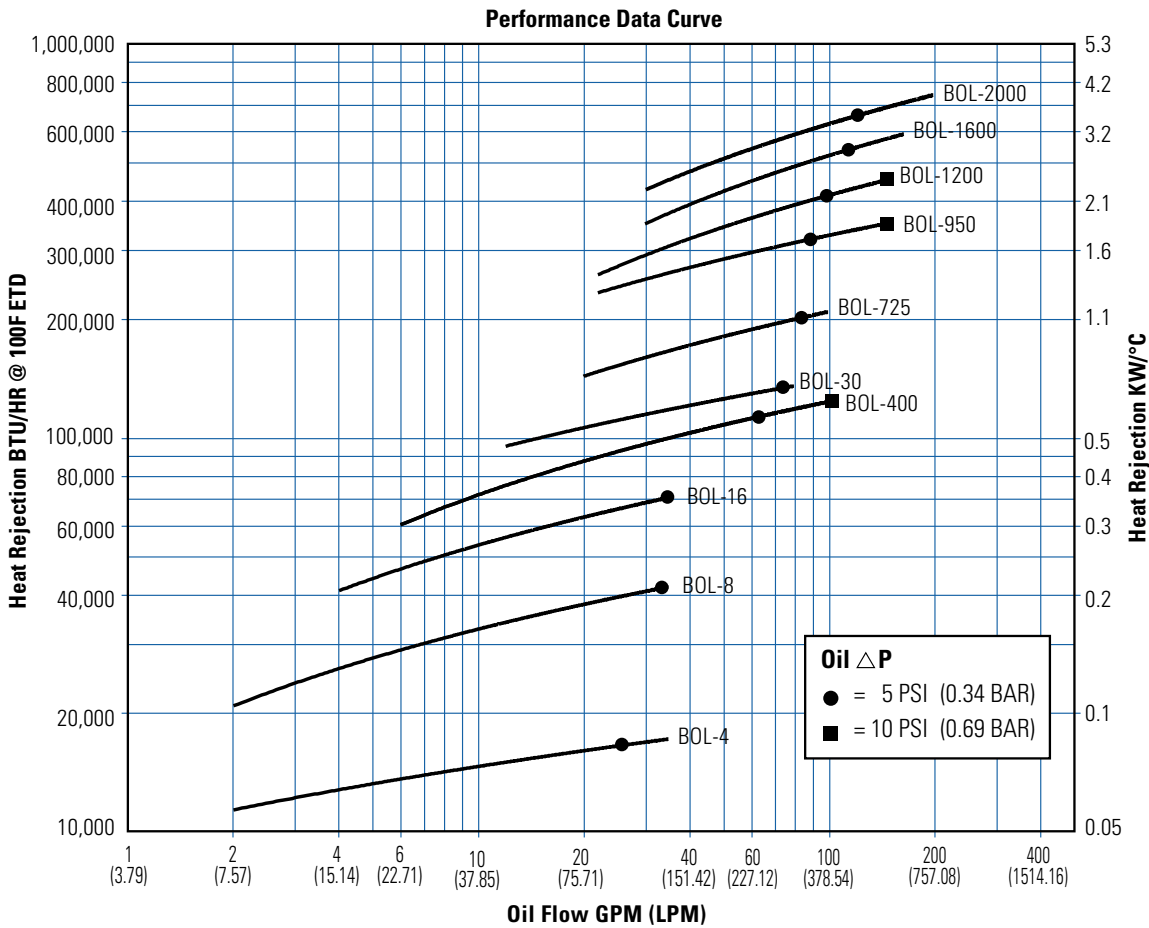

Note: Derate heat rejection values 15% if using 50Hz motors.

Pressure Drop

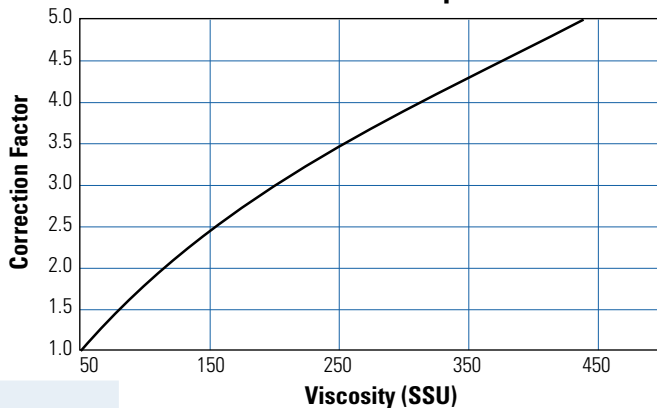

Oil Temperature

Typical operating temperature ranges are:

Hydraulic Motor Oil	120°F - 180°F (49°C - 82.2°C)
Hydrostatic Drive Oil	160°F - 180°F (71°C - 82.2°C)
Engine Lube Oil	180°F - 200°F (82.2°C - 93.3°C)
Automatic Transmission Fluid	200°F - 300°F (93.3°C - 149°C)

Desired Reservoir Temperature

Oil Temperature: Oil coolers can be selected using entering or leaving oil temperatures.

Off-Line Recirculation Cooling Loop: Desired reservoir temperature is the oil temperature entering the cooler.

Return Line Cooling: Desired reservoir temperature is the oil temperature leaving the cooler. In this case, the oil temperature change must be determined so that the actual oil entering temperature can be found.

Calculate the oil temperature change (oil ΔT) with this formula:

$$\text{Oil } \Delta T = (\text{BTU's/Hr.}) / (\text{GPM Oil Flow} \times 210).$$

To calculate the oil entering temperature to the cooler, use this formula:

$$\text{Oil Entering Temp.} = \text{Oil Leaving Temp.} + \text{Oil } \Delta T.$$

Oil Pressure Drop: Most systems can tolerate a pressure drop through the heat exchanger of 20 to 30 PSI. Excessive pressure drop should be avoided. Care should be taken to limit pressure drop to 5 PSI or less for case drain applications where high back pressure may damage the pump shaft seals.

Performance Curves

BOL Models with Low-Noise Option

The low noise option offers the BOL models with a reduced motor speed. This allows a lower sound level output for noise-sensitive applications.

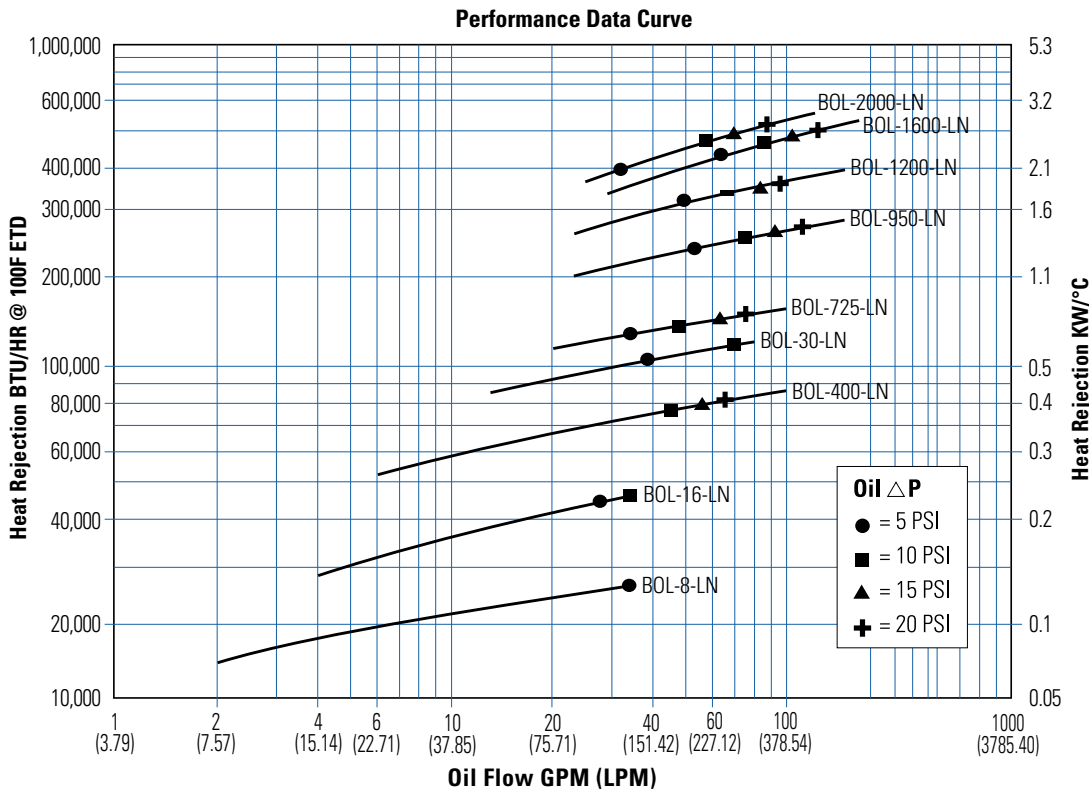

Available on 60 Hz Nema frame only.

Electric Motor Information

Model	HP	Frame	Low Noise RPM	Low Noise CFM	Low Noise CMM	Voltage	Frequency (HZ)
8-1PH	0.33	48	1725	400	11.33	115/230	60
8-3PH	0.33	48	1725	400	11.33	208-230/460	60
16-1PH	0.50	48	1725	704	19.93	115/230	60
16-3PH	0.50	48	1725	704	19.93	208-230/460	60
30-1PH	0.50	56C	1160	1470	41.62	115/230	60
30-3PH	0.50	56C	1160	1470	41.62	208-230/460	60
400-1PH	1.00	56C	1725	1100	31.19	115/230	60
400-3PH	1.00	56C	1725	1100	31.19	208-230/460	60
725-1PH	1.50	56C	1725	1780	50.40	115/230	60
725-3PH	1.50	56C	1725	1780	50.40	208-230/460	60
950-1PH	1.50	145TC	1160	3150	89.19	115/230	60
950-3PH	1.50	145TC	1160	3150	89.19	208-230/460	60
1200-3PH	3.00	182TC	1160	4690	132.81	208-230/460	60
1600-3PH	5.00	184TC	1160	6510	184.34	208-230/460	60
2000-3PH	5.00	213TC	1160	8700	000.00	230/460	60

Sound Data

Model	DBA at 3 ft
BOL-8-LN	67
BOL-16-LN	71
BOL-30-LN	80
BOL-400-LN	71
BOL-725-LN	75
BOL-950-LN	80
BOL-1200-LN	84
BOL-1600-LN	84
BOL-2000-LN	90

